



University-wide Student Exchange Program

CHECKLIST

**Notes for applicants**

- ◇ Read the Application Guidelines carefully before submitting your application
- ◇ Make sure to print out your application forms at the end of the online application (Step 2)
- ◇ Make sure to submit all the documents listed below including the documents uploaded to STEP 2 to the program coordinator.
- ◇ If any document is in a language other than English or Japanese, English translation must be attached.
- ◇ Application documents must be uploaded to Kyoto University's storage through the coordinator of your home university. (**Direct submission will NOT be accepted.**)

**Notes for exchange program coordinator**

- ◇ Application documents must be uploaded to Kyoto University's storage through the program coordinator before the deadline.
- ◇ **Please enclose this checklist with all required documents.**

**Name of University** \_\_\_\_\_

**Student Name** \_\_\_\_\_

Mandatory  Strongly Advised  Optional  (mark with "✓".)

Document	KUINEP	GEA	GESR
Online application pages (signed & dated)			
Recommendation letter ( <b>Form 1</b> ) *1			
Health certificate ( <b>Form 2</b> )			
Statement of purpose ( <b>Form 4</b> )	-		
Research plan essay (free format)	-	-	
Copy of TOEFL iBT or IELTS or JLPT (N1) <b>OR</b>			
Language proficiency statement ( <b>Form 5</b> )			
Copy of letter of provisional acceptance ( <b>Form 6</b> ) *2	-	-	
Academic transcript in English *3			
Copy of passport (personal particulars page)			
One recent portrait photo (size: H 4cm x W 3 cm) *4			
JASSO scholarship application form ( <b>Form 7</b> ) *5			
Confirmation note regarding security export control *6	-		

**NOTE: We accept only our designated forms (Form 1- 7), not any other format.**

- \*1) The recommendation letter should be written by a faculty/teaching member who currently belongs to the applicant's home university.
- \*2) Original should be kept by a faculty member of Kyoto University who issues the letter. The application may not be accepted by the graduate school if the applicant cannot obtain and submit the letter of provisional acceptance by the application deadline.
- \*3) If the academic transcript is not written in English, please submit the official transcript together with its translation, verified by the home university.
- \*4) Please check instructions on "Portrait Photo Requirement".
- \*5) If JASSO scholarship application is not submitted, we consider the student does not wish to apply for the scholarship even if s/he selects "I wish to apply" in the online application STEP 1.
- \*6) This is only required for those who apply for the Graduate School of Informatics.

## Portrait Photo Requirement

Please upload a recent portrait photo in size and conditions specified below to the online application STEP 2 and submit it as data (jpeg) to the program coordinator.

**This will be used for the application form for the Certificate of Eligibility (CoE) submitted to the Immigration bureau, and your student ID card.**

**The photo that doesn't meet the following conditions will not be accepted by the Immigration bureau and may be requested to be resubmitted.**

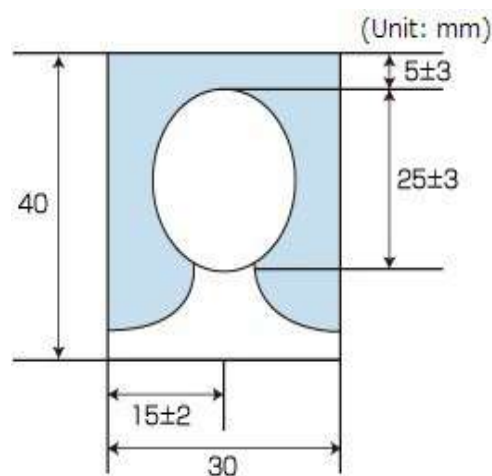

1. A photo that shows the applicant him/herself alone.
2. A photo of the dimensions specified in the drawing above, excluding the photo's outer border (the dimension of the face refers to the portion from the top of the head [including the hair] to the lower end of the chin).
3. The person should face squarely to the front and remove hats, caps or head coverings.
4. No background or shadows.
5. Must be clear.
6. Must be taken within one month prior to submission.
7. Must be different from the one on your passport.
8. Photo resolution 300dpi or higher (jpeg)

## Passport Requirement

Please upload a copy of passport in conditions specified below to the online application STEP 2 and submit it to the program coordinator.

**This will be used for the application form for the Certificate of Eligibility (CoE) submitted to the Immigration bureau.**

**The passport that doesn't meet the following conditions will not be accepted by the Immigration bureau and may be requested to be resubmitted.**

1. The copy must contain all the information in the frame (top & bottom and both ends).
2. The passport should be copied or scanned instead of taking photo to avoid light reflections, shadows, deformation and low resolution etc.



**NOTE:**

- If your passport has already expired or is about to expire and doesn't cover the entire period of the exchange program, please upload the old/current passport to STEP 2 and apply for a new passport as soon as possible.

In this case, we are going to proceed with your application with the old/current passport while waiting for the new passport so, please let us know when you can submit your new passport.

- \* Spring (1<sup>st</sup>) semester will end early August including the period of the exams
- \* Fall (2<sup>nd</sup>) semester will end early Feb including the period of the exams
- If you have never had a passport and are currently applying or going to apply, please email us.

## LETTER OF RECOMMENDATION

## 推薦書

To: The President of Kyoto University  
京都大学総長 殿

I am pleased to recommend Mr./Ms. \_\_\_\_\_ as a candidate for Kyoto University Exchange Program.

下記の者を貴学の交換留学プログラム生として適当であると認め、候補者として推薦します。

Full name of candidate:

(氏名)

\_\_\_\_\_ , \_\_\_\_\_

(Last Name)

(First Name)

(Middle Name)

Reasons for Recommendation (推薦理由) :

<Please describe applicant's academic performance and/or personality inside and/or outside classes>

Signature

(署名) \_\_\_\_\_

Name in print

(氏名) \_\_\_\_\_

Job Title or Position

(肩書) \_\_\_\_\_

Name of University

(在籍大学) \_\_\_\_\_

Date

(日付) \_\_\_\_\_

Year / Month / Day

**\*\*IMPORTANT\*\***: This form should be written and signed by a faculty/teaching member who currently belongs to the applicant's home university.

## HEALTH CERTIFICATE 健康診断書

Full Name: \_\_\_\_\_  
(氏名)

Date of Birth: \_\_\_\_\_  
(生年月日) Year / Month / Day

### To the student (参加学生へ) :

Please answer the questions below **by O (circling) “Yes” or “No”**, before submitting to a physician for your physical examination. (健康診断を医師に申込む前に下記の設問に関しいずれかをチェックしてください。)

1. What diseases, disorders or injuries have you had in the past five years? (過去5年間にかった病気、あるいは怪我の名を書いてください。) ( )
2. Do you have any allergies to foods, plants or animals? (食物、動植物にアレルギーはありますか。) Yes / No
3. Have you ever had an adverse reaction to medication? (薬に対してアレルギーはありますか。) Yes / No
4. Are you taking medication now? (現在、何か薬を飲んでいますか。) Yes / No

### To the physician (医師の方へ) :

Please review the applicant's medical history and complete the information below, giving details concerning any positive indications. (患者の病・傷害歴をお読みになってから診断、ご記入ください。)

Please circle the appropriate answer and explain in detail in English if there are any impairment in the following systems. (各項目につき+か-いずれかを○で囲んでください。もし何か所見がみられれば英語で詳しくお書きください。)

		Normal/Impaired (正常/異常)	Describe the condition in detail (in English) <b>only if “Impaired”</b> (特筆すべき所見があれば記入してください)
1.	Head/Ears/Nose/Throat (頭/耳/鼻/喉)	Normal/Impaired	
2.	Respiratory (呼吸器)	Normal/Impaired	
3.	Cardiovascular (心臓/血管)	Normal/Impaired	
4.	Eyes (目)	Normal/Impaired	
5.	Genitourinary (泌尿生殖器)	Normal/Impaired	
6.	Musculoskeletal (筋/骨)	Normal/Impaired	
7.	Metabolic/Endocrine (代謝/分泌)	Normal/Impaired	
8.	Neuropsychiatric including learning disabilities (神経精神/学習障害など)	Normal/Impaired	
9.	Skin (皮膚)	Normal/Impaired	
10.	Other System		

After reviewing the applicant's medical history and physical condition, I believe him/her to be in good physical and mental health, free of any chronic conditions, disorders or contagious diseases, and capable physically and mentally of completing a one or two semester term of study in Kyoto University.

(患者の病歴と健康状態を診た結果、私は上記の者が、肉体的にも精神的にも健康で、持病、伝染病、身体の不調無く、京都大学で1、2学期間、勉強を続けるのに支障はないと確信します。)

医療機関印  Official Stamp of Institution/Clinic	Date (診断日) _____
	Institution/Clinic (医療機関名) _____
	Address (所在地) _____
	Name of Physician (医師氏名) _____
	Signature (署名) _____



University-wide Student Exchange Program  
Application Guidelines

AY 2025 Fall (2<sup>nd</sup>) Semester (Exchange Period: Oct 2025 - Mar 2026/Sep 2026)

**Table of Contents**

1. Outline of Exchange Programs.....	2
2. Affiliation.....	3
3. Academic Calendar.....	4
4. Eligibility.....	4
5. Language Requirement *IMPORTANT*.....	4
6. Letter of Provisional Acceptance (GESR only) *IMPORTANT*.....	4
7. Tuitions.....	5
8. Scholarship.....	5
9. VISA.....	5
10. Medical Situation and Insurance.....	5
11. Accommodation.....	6
12. Academic Transcript and Credits (KUINEP & GEA).....	6
13. Course Registrations.....	7
14. Japanese Language courses (OPTIONAL).....	8
15. Application Procedures.....	9
16. Application Documents *We ONLY accept the designated forms (Form 1 – Form 7).....	9

**Exchange Program Office**

International Education and Student Mobility Division, Kyoto University  
Address : Yoshida Nihonmatsu-cho, Sakyo-ku, Kyoto, 606-8501 JAPAN  
Telephone : +81-(0)75-753-2546  
E-mail : [inbound.exchange@mail2.adm.kyoto-u.ac.jp](mailto:inbound.exchange@mail2.adm.kyoto-u.ac.jp)

**//Important//**

Completing an application does not guarantee admission into the program due to capacity issues.

**Important Dates and Deadlines**

For AY 2025 Fall (2nd) Semester

- Call for Nomination : December 2024
- Nomination Deadline : By **January 17**, 2025 (online)
- Application Deadline : By **February 14**, 2025 (online **and** \*data)
- Application Outcome : July 2025 (e-mail)

**\* Data**

The way of submission: Instead of sending by postal mail, upload all the application documents to Kyoto University storage through coordinator after students complete online application steps (STEP 1 & STEP2).

## 1. Outline of Exchange Programs

Kyoto University offers two different types of student exchange programs, KUINEP and GE program, under the university-wide student exchange agreement. Students are expected to choose which program they belong to with advice from their home institution.

**KUINEP**: Kyoto University International Education Program (Only for undergraduates)

**GE program**: General Exchange program (**GEA** or **GESR**)

Program	Category	Level	Activity	Language Requirement
KUINEP	KUINEP	Undergraduate	Coursework	English
GE program	GEA	Undergraduate	Coursework	Japanese
		Master/Doctor	Coursework	Japanese (or English*)
	GESR	Master/Doctor	Research	(depends on supervisor)

### Kyoto University International Education Program (KUINEP)

The Kyoto University International Education Program (KUINEP) is available for undergraduate students and provides undergraduate level lectures in English to our partner university students as well as Kyoto University students. Although KUINEP students in principle can choose from every KUINEP courses regardless their year in Home University, these courses are mainly designed for 1st and 2nd year of the undergraduate students of the Japanese educational standards. Approximately 65% of the courses are targeted at 1st and 2nd year students and the rest are targeted at every student (1st to 4th). KUINEP students are required to take a minimum of seven courses each semester mainly from KUINEP courses offered by the Institute for Liberal Arts and Sciences (ILAS) taught in English and additionally from courses offered by Faculties with the lecturer's permission. Students are affiliated to the Institute for Liberal Arts and Sciences (ILAS) as "Special Auditor".

### Kyoto University General Exchange Program (GE program)

The Kyoto University General Exchange Program (GE program) is available for undergraduate and graduate students. Students are affiliated to one of undergraduate faculties or graduate schools, and choose all or most of courses from those offered by their own undergraduate faculties or graduate schools ("Special Auditor": GEA) or deepen their own research under the instruction of academic supervisors without taking any courses lectured in classrooms ("Special Research Student": GESR). Undergraduate GEA is required to take a minimum of seven courses each semester while graduate GEA is required to take a minimum of four courses. GESR students do not need Japanese proficiency if the supervisor can guide the student in any other language. GESR is available only for graduate students.

#### \* For graduate GEA students

Some graduate schools provide limited number of courses lectured in English. It is occasionally possible to be a GEA student without having sufficient Japanese language proficiency, if graduate students are able to find enough numbers (at least four per semester) of such courses to match the subject they wish to study at Kyoto University. If they would like to see whether their intended graduate school offers enough courses lectured in English, please access the URL below.

#### Course Search (Syllabi):

[https://www.k.kyoto-u.ac.jp/external/open\\_syllabus/top?display\\_lang=en](https://www.k.kyoto-u.ac.jp/external/open_syllabus/top?display_lang=en)

#### List of English courses available for "the Graduate School of Engineering":

<https://fsv.iimc.kyoto-u.ac.jp/public/mfo5gWkXwyurpYDoXXCZJskArEJ0GrerpCUQwhDFaMn5>



Please note that the Spring semester is the first semester (from April to September) and the Fall semester is the second semester (from October to March) at Kyoto University.

## 2. Affiliation

Each KUINEP, GEA, and GESR will be affiliated to one of the faculties or graduate schools at Kyoto University based on the major field of study at the home institution.

- It is not allowed to change the program nor the affiliation after the application deadline.
- It is a policy in principle of Kyoto University not to allow exchange students to enroll in the faculty/graduate school without having their background in their home universities.
- A transcript for KUINEP and GEA students will be issued under the name of each faculty/graduate school. (e.g. KUINEP students will receive transcripts issued by the Institute for Liberal Arts and Sciences.)

### KUINEP (Undergraduate) – taught in English

Faculty	Website
Institute for Liberal Arts and Sciences	<a href="http://www.z.k.kyoto-u.ac.jp/">http://www.z.k.kyoto-u.ac.jp/</a>

### GEA (Undergraduate) – taught in Japanese(\*should have JLPT N1 level or equivalent)

Faculty	Website
Integrated Human Studies	<a href="http://www.h.kyoto-u.ac.jp/en/ug/">http://www.h.kyoto-u.ac.jp/en/ug/</a>
Letters	<a href="http://www.bun.kyoto-u.ac.jp/en/">http://www.bun.kyoto-u.ac.jp/en/</a>
Education	<a href="https://www.educ.kyoto-u.ac.jp/en/">https://www.educ.kyoto-u.ac.jp/en/</a>
Law	<a href="http://law.kyoto-u.ac.jp/english/">http://law.kyoto-u.ac.jp/english/</a>
Economics	<a href="http://www.econ.kyoto-u.ac.jp/en/">http://www.econ.kyoto-u.ac.jp/en/</a>
Science	<a href="http://www.sci.kyoto-u.ac.jp/en/">http://www.sci.kyoto-u.ac.jp/en/</a>
Pharmaceutical Science	<a href="http://www.pharm.kyoto-u.ac.jp/en/">http://www.pharm.kyoto-u.ac.jp/en/</a>
Engineering	<a href="https://www.t.kyoto-u.ac.jp/en">https://www.t.kyoto-u.ac.jp/en</a>
Agriculture	<a href="http://www.kais.kyoto-u.ac.jp/english/">http://www.kais.kyoto-u.ac.jp/english/</a>

### GEA (Graduate) / GESR – taught in Japanese/English

Graduate School	Website
Letters	<a href="http://www.bun.kyoto-u.ac.jp/en/">http://www.bun.kyoto-u.ac.jp/en/</a>
Education	<a href="https://www.educ.kyoto-u.ac.jp/en/">https://www.educ.kyoto-u.ac.jp/en/</a>
Law	<a href="http://law.kyoto-u.ac.jp/english/">http://law.kyoto-u.ac.jp/english/</a>
Economics	<a href="http://www.econ.kyoto-u.ac.jp/en/">http://www.econ.kyoto-u.ac.jp/en/</a>
Science	<a href="http://www.sci.kyoto-u.ac.jp/en/">http://www.sci.kyoto-u.ac.jp/en/</a>
Pharmaceutical Science	<a href="http://www.pharm.kyoto-u.ac.jp/en/">http://www.pharm.kyoto-u.ac.jp/en/</a>
Engineering	<a href="http://www.t.kyoto-u.ac.jp/en">http://www.t.kyoto-u.ac.jp/en</a>
Agriculture	<a href="http://www.kais.kyoto-u.ac.jp/english/">http://www.kais.kyoto-u.ac.jp/english/</a>
Human and Environmental Studies	<a href="https://www.h.kyoto-u.ac.jp/en/gr/">https://www.h.kyoto-u.ac.jp/en/gr/</a>
Energy Science	<a href="https://www.energy.kyoto-u.ac.jp/en/">https://www.energy.kyoto-u.ac.jp/en/</a>
Asian and African Area Studies	<a href="http://www.asafas.kyoto-u.ac.jp/en/">http://www.asafas.kyoto-u.ac.jp/en/</a>
Informatics	<a href="http://www.i.kyoto-u.ac.jp/en/">http://www.i.kyoto-u.ac.jp/en/</a>
Biostudies <b>*GESR only</b>	<a href="http://www.lif.kyoto-u.ac.jp/e/">http://www.lif.kyoto-u.ac.jp/e/</a>
Advanced Integrated Studies in Human Survivability	<a href="http://www.gsais.kyoto-u.ac.jp/en-top/">http://www.gsais.kyoto-u.ac.jp/en-top/</a>
Global Environmental Studies	<a href="http://www2.ges.kyoto-u.ac.jp/en/?ml_lang=ja/en/">http://www2.ges.kyoto-u.ac.jp/en/?ml_lang=ja/en/</a>

Government <b>*GEA only</b>	<a href="https://www.sg.kyoto-u.ac.jp/sg/?lang=en">https://www.sg.kyoto-u.ac.jp/sg/?lang=en</a>
Management <b>*GEA only *up to 2 students per semester from each partner</b>	<a href="http://www.gsm.kyoto-u.ac.jp/en">http://www.gsm.kyoto-u.ac.jp/en</a>

### 3. Academic Calendar

	AY 2025 Fall (2nd semester)	AY 2026 Spring (1st semester)
Semester period	Oct 1, 2025 – Mar 31, 2026	Apr 1, 2026 – Sep 30, 2026
Arrival	After Sep 15 (tba)	(tba)
Dormitory move-in	Sep 27 (tba)	(tba)
Online Orientation	Late September	(tba)
Classes	Oct 1–Jan 26	early Apr – late Jul (tba)
Examination	Jan 27–Feb 9	late Jul – early Aug (tba)
Summer/Spring break	Feb 10– Mar 31	early Aug – Sep 30 (tba)

- Courses are designed according to the Japanese academic calendar, i.e. from Apr-Sep (Spring/1<sup>st</sup> semester) and Oct-Mar (Fall/2<sup>nd</sup> semester). A few courses are designed for consecutive two semesters from Apr-Mar (Spring/1<sup>st</sup> & Fall/2<sup>nd</sup>).
- Students may enroll for up to two consecutive semesters, starting in either Fall or Spring, with approval from their home universities.
- Students may return to their country after their classes and exams end.

### 4. Eligibility

Exchange applicant should:

- 1) Have achieved a cumulative GPA of 3.0 or above on a 4.0 scale or its equivalent
- 2) Be enrolled, until completion of the exchange program, as a regular student at a non-Japanese academic institution with which Kyoto University has a university-wide student exchange agreement
- 3) Return to his/her home university on the completion of the exchange program
- 4) Have an excellent academic and disciplinary standing
- 5) Prove their language proficiency required to attend the exchange program
- 6) Have a concrete purpose of studying at Kyoto University

### 5. Language Requirement **\*IMPORTANT\***

	Taking classes in English	Taking classes in Japanese	Focusing on research
KUINEP	TOEFL iBT 79 or IELTS 6.5	-	-
GEA		<b>*JLPT N1</b>	-
GESR	-	-	TOEFL iBT 79, IELTS 6.5 or JLPT N1

- All applicants, **including** native English speakers, who take classes offered in English should submit a valid TOEFL iBT or IELTS scores taken within two years, **OR** the language proficiency statement (Form 5), regardless of whether those institutions are located in an area where English is the first language or the institutions use English as the medium of instruction.
- All applicants, **including** native Japanese speakers, who take classes offered in Japanese should submit a JLPT score with grade "N1" taken within two years **OR** the language proficiency statement (Form 5). **\*Undergraduates who would like to apply for GEA need to have achieved JLPT N1 or equivalent at the time of nomination/application.**

### 6. Letter of Provisional Acceptance (GESR only) **\*IMPORTANT\***

Upon approval by the home university, GESR applicants shall directly contact the provisional academic advisor under whom they wish to conduct their research and request the issuance

of the letter of provisional acceptance (Form 6). Students are strongly encouraged to send their research plans together with "Form 6" when they contact. **The application may not be accepted by the graduate school if the applicant cannot obtain and submit the letter of provisional acceptance by the application deadline.**

## **7. Tuitions**

Based on the student exchange agreement, the exchange students are exempted from examination fee, matriculation fee and tuition fee at Kyoto University.

## **8. Scholarship**

If Kyoto University are granted the fund for Scholarship by JASSO, a limited number of applicants may be able to receive the scholarship through JASSO (Japan Student Services Organization), a government-sponsored non-profit organization to promote international student exchange. Recipients of the JASSO scholarship will be selected by Kyoto University based on their academic record and financial condition. Students are *not* eligible to apply for JASSO scholarship if they will receive any other financial support more than 80,000 yen per month to study abroad or if they do not have the residence status of "Student", i.e. those who have Japanese nationality or permanent residency are not eligible to apply for JASSO scholarship. Since the application result for JASSO will only be available on/after their arrival, exchange students should be financed enough to apply for the exchange program. Please note that this scholarship is available only when Kyoto University is funded by JASSO.

## **9. VISA**

Students must possess a valid passport issued by their home country. Kyoto University will apply for exchange students' "Certificate of Eligibility (CoE)" to the Kyoto Immigration Bureau for processing. Students, on receiving their CoE, should apply to the nearest Japanese diplomatic mission (embassy or consulate) in their own country or country of residence for a "Student" visa, and enter Japan with the residence status of "Student". As instructed by the immigration office, students who possess Japanese nationality or Japanese and a foreign nationality must enter Japan with a Japanese passport. Students with permanent residency do not need to obtain a "Student" visa.

## **10. Medical Situation and Insurance**

Please be advised that we do not have a medical facility on campus that provides consultations, medical care or medications to students, and our health care office only provides primary clinical care in emergency situations. We have a department that offers counseling for mental health issues; however, they cannot prescribe medication as it is not a medical facility. If any physical or mental health issues arise, students need to seek medical care off campus. However, please note that there are a limited number of off-campus medical facilities that can provide English-language services (especially mental health).

Students should consider this medical situation in Japan and their own health conditions before applying to our exchange program.

The Japanese law specifies that students staying in Japan for more than three months must join the Japanese National Health Insurance Program, which costs around 2,000 yen per month.

When entering Kyoto University, students must join the "University CO-OP Personal Liability Insurance for Students (*Gakubai*)". Yearly premium for *Gakubai* is around 2,000 yen plus initial CO-OP membership fee of 4,000 yen. (The membership fee will be fully refunded upon deregistration.) In addition, the students should take out travel insurance from their countries before coming to Japan.

We recommend students to bring along sufficient funds in case of any emergency (There

was a case where a student had an operation and needed to settle a huge amount of medical fees temporarily.).

## 11. Accommodation

There are one on-campus and five off-campus International Houses of Kyoto University and other dormitories offered for international students. However, they are not guaranteed and are subject to availability due to limited housing capacity. As of Fall 2024, 70% of the exchange students were allocated a dorm room on a lottery-basis.

All exchange students will receive detailed information on applying for dormitories after they are officially accepted for the program. Application period starts around three months before their arrival. However, students who will turn out not to be allocated a dorm room will be asked to find a place to live by themselves using the following website, etc..

Kyoto University lodging facilities: <https://kuiso.oc.kyoto-u.ac.jp/housing/facilities/en>

Other Housing Information: <https://kuiso.oc.kyoto-u.ac.jp/en/housing/info/>

## 12. Academic Transcript and Credits(KUINEP & GEA)

(\*GESR students don't earn credits nor transcript)

### (1) Transcript Issue Date

Official transcript for students taking courses will be issued only after the semester period ends, i.e. in early October for spring semester and in early April for fall semester.

	AY 2025 Fall (2nd semester)	AY 2026 Spring (1st semester)
Semester period	Oct 1, 2025 – Mar 31, 2026	Apr 1 – Sep 30, 2026
Transcript	Early April 2026	Early October 2026

### \*IMPORTANT\*

No transcripts can be issued before the above timeline in any circumstances. It is strongly recommended for exchange students especially at the graduating year to plan well in advance that they will not be able to receive the transcript before the above timeline.

### (2) Grading Scale

Letter grades ranging from "A+" to "-" are used to report the standing of a student upon the completion of each semester.

**A+** 96–100 %   **A** 85–95 %   **B** 75–84 %   **C** 65–74 %   **D** 60–64 %

- (Fail: 59% or less) \*

\*No credits awarded and will not show on official transcripts.

### (3) Workload standard

One credit is generally equivalent to 45 hours of workload per semester which includes all learning activities, for example, lectures, tutorials, assignments and preparation. At Kyoto University, one period of class is considered to be corresponding to two hours and two credits per course per semester are granted in principle.

1 credit = 45 hours of workload

1 course = (2 hours in class + 4 hours for preparation) \*15 weeks per semester  
= 90 hours = 2 credits

#### (4) Minimum Number of Courses

Exchange students enrolled in KUINEP and undergraduate GEA programs are required to take a minimum of seven courses each semester. This can include up to two Japanese language courses (credited courses) *\*refer to "14. Japanese Language courses"*.

Graduate GEA students are required to take a minimum of four courses each semester, **not** including Japanese language courses.

	Category	Minimum number of courses required each semester	Remarks
Undergraduate	KUINEP	7	May include up to two Japanese language courses
	GEA	7	May include up to two Japanese language courses
Graduate	GEA	4	Japanese language courses are <b>not</b> counted toward this number
	GESR	(not applicable)	Focus on research (cannot register for courses)

### 13. Course Registrations

	Category	Undergraduate			Graduate	
		KUINEP courses	Courses offered by your assigned faculty	Courses offered by other faculty	Courses offered by your assigned graduate school	Courses offered by other graduate school
Undergraduate	KUINEP	●	-	○	-	-
	GEA	○	●	○*1	-	-
Graduate	GEA	-	-	-	●*2	○*1,2
	GESR	-	-	-	-	-

●: Mandatory ○: Optional

\*1 Students belonging to "The Faculty/Graduate School of Engineering" are not eligible.

\*2 Although very limited, but some graduate schools offer courses in English. Syllabi or the list of courses at each faculty/graduate school will only be available in the end of March.

#### KUINEP

KUINEP students are required to take a minimum of seven courses each semester mainly from the Liberal Arts and Sciences courses taught in English (KUINEP courses). They can also take courses offered by undergraduate faculties with the lecturer's permission. Courses of Faculty of Medicine are not open to exchange students.

#### GEA (Undergraduate)

Undergraduate GEA is required to take a minimum of seven courses each semester mainly from the faculty they belong to. They can also take the Liberal Arts and Sciences courses and courses offered by undergraduate faculties they are not enrolled in with the lecturer's permission. However, GEA students accepted by "the Faculty of Engineering" are allowed to take only courses offered by "the Faculty of Engineering" and "the Liberal Arts and Sciences" in principle. Taking courses offered by other faculties they are not enrolled in should be limited to those deemed necessary and approved by their academic supervisor at Kyoto University.

Courses of the Faculty of Medicine are not open to exchange students.

## **GEA (Graduate)**

Graduate GEA are required to take a minimum of four courses each semester mainly from the graduate school they belong to. They can also take courses offered by graduate schools they are not enrolled in with the lecturer's permission as long as these are available for exchange students. However, GEA students accepted by "the Graduate School of Engineering" are allowed to take only courses offered by "the Graduate School of Engineering" in principle. Taking courses offered by other Graduate Schools they are not enrolled in should be limited to those deemed necessary and approved by their academic supervisor at Kyoto University.

Courses of the Graduate School of Medicine are not open to exchange students.

### **Important (KUINEP and GEA)**

- Undergraduate students are not eligible to take courses designed for graduates and vice versa.
- Syllabi are subject to change.
- Course registration starts only after the semester period begins.
- Some seminars and courses involving practical training or experiments may preclude exchange students because of the limited number of students who are allowed to take them, on the basis of priority for regular students.
- There are courses which are not open to exchange students and some courses open to exchange students might also implement enrollment restrictions. Therefore, exchange students are strongly advised to be as flexible as possible in their course selection.
- Our program is not a good fit for exchange students relying on specific courses to graduate on time.

## **GESR**

Exchange students who are enrolled in a graduate school of Kyoto University as "Special Research Student" (GESR) under supervision of an academic advisor, cannot take any courses including credited Japanese language courses.

## **14. Japanese Language courses (OPTIONAL)**

Japanese language courses are offered by the Institute for Liberal Arts and Sciences (ILAS). These consist of (1) credited courses and (2) non-credited courses.

### **(1) Credited Japanese language courses (for KUINEP and GEA)**

- KUINEP and GEA students can take a maximum of **four** Japanese language courses (**8** credits) each semester. (4H and 8H courses are considered as two and four courses respectively and other Japanese language courses are considered as one course.)
- GESR students are not eligible to take credited courses.
- Evaluation for credited courses will be recorded in the official transcript.
- Two official credits will be conferred for each course.
- Students will be required to take an online placement test before coming to Kyoto University to determine their level of Japanese language proficiency.

For more information:

<http://www.z.k.kyoto-u.ac.jp/introduction/education-center-for-japanese/japanese-language-classes/zenkyo-japanese/for-kokanryuugakusei>

### **(2) Non-Credited Japanese language courses (for GESR)**

- Non-credited courses are available for GESR only.

- KUINEP and GEA students are not eligible to take non-credited courses.
- These courses are not included in the regular curriculum.
- No evaluation will be made, i.e. no scores nor credits will be available.

For more information:

<https://www.z.k.kyoto-u.ac.jp/introduction/education-center-for-japanese/japanese-language-classes/learning-support>

**\*All information collected through application will be used solely for admission purposes and administrative purposes such as education research activities, student support, health management, enrollment in insurances, use of university facilities, and other related to work as deemed necessary and will be shared only as required with limited personnel who have a need to have access to such information while fulfilling Kyoto University's requirements under Personal Information Protection Law and will not be used for any other purpose.**

## 15. Application Procedures

Nominations must be submitted through the Kyoto University online nomination system by the exchange program coordinator at the home university. Only the documents submitted from the office of the partner university will be accepted.

Step	Spring (Apr-)	Fall (Oct-)
<b>KU:</b> Send nomination link to <b>HU</b>	June	December
<b>HU:</b> Nominate <b>ES</b> to <b>KU</b>	August	January
<b>KU:</b> Send application "Step 1" link to <b>ES</b> and <b>HU</b>	(1 month)	(1 month)
<b>ES:</b> Complete online application "Step 1"		
<b>KU:</b> Send application "Step 2" link to <b>ES</b> and <b>HU</b>		
<b>ES:</b> Complete "Step 2"		
<b>ES:</b> Submit all application documents to <b>HU</b>		
<b>HU:</b> Upload all the documents to <b>KU's</b> storage	September	February
<b>KU:</b> Send acceptance letter etc. to <b>ES</b> & <b>HU</b> by e-mail	January	July
<b>KU:</b> Send visa documents to <b>ES</b>	By Early Mar	By Early Sep

**KU:** Kyoto University    **HU:** Home University    **ES:** Exchange Student

## 16. Application Documents **\*We ONLY accept the designated forms (Form 1 – Form 7)**

Documents	KUINEP	GEA	GESR
Online application pages (signed & dated)	●	●	●
Recommendation letter ( <b>Form 1</b> ) *1	●	●	●
Health certificate ( <b>Form 2</b> )	●	●	●
Statement of purpose ( <b>Form 4</b> )	-	●	●
Research plan essay (free format)	-	-	●
Copy of TOEFL iBT or IELTS or JLPT (N1) <b>OR</b>	●	●	●
Language proficiency statement ( <b>Form 5</b> )			
Copy of letter of provisional acceptance ( <b>Form 6</b> ) *2	-	-	◎
Academic transcript in English *3	●	●	●
Copy of passport (personal particulars page)	●	●	●
One recent portrait photo (size: H 4cm x W 3 cm) *4	●	●	●
JASSO scholarship application form ( <b>Form 7</b> ) *5	○	○	○
Confirmation note regarding security export control *6	-	●	●

(●: Mandatory    ◎: Strongly Advised    ○: Optional)

- \*1) The recommendation letter should be written by a faculty/teaching member who currently belongs to the applicant's home university.
- \*2) Original should be kept by a faculty member of Kyoto University who issued the letter. The application may not be accepted by the graduate school if the applicant cannot obtain and submit the letter of provisional acceptance by the application deadline.
- \*3) If the academic transcript is not written in English, please submit the official transcript together with its translation, verified by the home university.
- \*4) Please check instructions on "Portrait Photo Requirement".
- \*5) If JASSO scholarship application is not submitted, we consider the student does not wish to apply for the scholarship even if s/he selects "I would like to apply" in the online application form.
- \*6) This is only required for those who apply for the Graduate School of Informatics.

\* Certificate of Enrollment(Form3) will no longer be required.





University-wide Student Exchange Program  
Application Guidelines – FAQ

**EXCHANGE PROGRAM**

**Q1: Can I change my exchange program (e.g. from KUINEP to GEA) and/or the affiliated faculty or graduate school after my application is submitted to Kyoto University?**

It is not allowed to change the program nor the affiliation after the application deadline for any reason.

**Q2: I am applying for a full year (two semesters) exchange program. Can I change my exchange program (e.g. from KUINEP to GEA) and/or the affiliated faculty or graduate school for the second semester?**

It is not allowed to change the program nor the affiliation during your exchange period.

**Q3: I am applying for GESR program (research program), but I also would like to take courses.**

GESR students are not eligible to take courses but focus on research activities. If you wish to take courses seeking credits, please apply for GEA program (no research activity).

**Q4: I am an undergraduate student and don't have Japanese proficiency, can I apply for GEA and take courses conducted in English?**

No, you cannot. If you would like to apply to GEA, you need to have Japanese proficiency (JLPT N1 level or equivalent) at the time of nomination/application. Undergraduate students who don't have Japanese proficiency, need to apply for KUINEP.

**COURSE REGISTRATION**

**Q5: Is it possible to take only Japanese language courses (courses to study Japanese language) during the exchange period?**

No, it is not possible. Exchange students enrolled in KUINEP and undergraduate GEA programs are required to take a minimum of seven courses each semester. This can include up to two Japanese language courses (credited courses). Graduate GEA students are required to take four courses each semester, not including Japanese language courses.

**Q6: I am applying for KUINEP program, but I also would like to take courses from the faculty other than Liberal Arts and Sciences courses.**

It is possible to register faculty courses during the actual course registration after your arrival, however, for the online application process, please select all courses from Liberal Arts and Sciences.

**Q7 I am an undergraduate student, am I allowed to take graduate courses?**

No, you are not. Undergraduate students are not allowed to take courses offered by graduate schools.

**Q8: I am a graduate student, am I allowed to take faculty courses or/and courses offered by the Institute for Liberal Arts and Sciences (ILAS)?**

No, you are not. Graduate students are not allowed to take courses offered by faculties nor ILAS.

**Q9: I would like to know in advance whether the courses I selected during application are available for exchange students as I need to have course approval from my home university.**

The courses you have selected during application process are for us to see the area of your interest. Actual course registration will be done only after your arrival here. Please also note that syllabi are subject to change and some courses may have restrictions for registration such as number of students or may not be available for exchange student. Please be as flexible as possible for the course selection and consider second choices and make backup plans.

**Q10: When do I register for the courses?**

Course registration process starts only after the semester period starts, except Japanese language courses which starts around one month before the semester period starts. Further detail will be explained after acceptance notice.

## APPLICATION DOCUMENTS

**Q11: I have academic transcript which is not the official one. Can I use it for my application?**

We only accept official academic transcript or a transcript with an evidence to certify that it was formally issued by your home institution, such as through a watermark or logo/crest. Please also note that we only accept transcripts in English. If your original transcript is not in English, you must provide an official translation.

**Q12: I cannot get the health certificate by the application deadline. What can I do?**

Please inform to your coordinator and contact the IESMD office by e-mail.

**Q13: Is it possible to submit the application documents in a format other than the designated forms of Kyoto University?**

No, it is not possible. We only accept the application documents in the designated forms (Form 1- Form 7) of Kyoto University. No other forms are acceptable.

## LANGUAGE PROFICIENCY (ENGLISH)

**Q14: I do not have TOEFL iBT or IELTS score, but I am studying at a university whose language of instruction is English. Do I need to submit English proficiency test scores?**

Please submit the language proficiency statement (Form 5). If you have any other English test score other than TOEFL iBT or IELTS, please attach these to the Form 5.

**Q15: Is it possible to submit the English test score other than TOEFL iBT or IELTS?**

If the score is equivalent to TOEFL iBT 79 or IELTS 6.5 or above, we will accept it. Please submit the language proficiency statement (Form 5) and attach the score you have.

**Q16: The only English test score I have has already expired. Can I use it for my application?**

Please submit the language proficiency statement (Form 5) and attach the expired score.

## LANGUAGE PROFICIENCY (JAPANESE)

**Q17: I do not have JLPT score, but I am studying at a university whose language of instruction is Japanese. Do I need to submit Japanese proficiency test scores?**

Please submit the language proficiency statement (Form 5). If you have any other Japanese test score other than JLPT, please attach these to the Form 5.

**Q18: Is it possible to submit the Japanese test score other than JLPT?**

If the score is equivalent to JLPT N1 (e.g. JPT660 or above) or above, we will accept it. Please submit the language proficiency statement (Form 5) and attach the score you have.

**Q19: The only JLPT score I have is taken more than two years before. Can I use it for my application?**

Please submit the language proficiency statement (Form 5) and attach the score you have.

**Q20: I do not have JLPT score. Am I still able to take courses taught in Japanese?**

As long as your Japanese language proficiency is equivalent to JLPT N1 or above, we will accept it. Please submit the language proficiency statement (Form 5).

## VISA/PASSPORT

**Q21: When will the Certificate of Eligibility for my VISA application be sent to me?**

Kyoto University will apply for exchange students' "Certificate of Eligibility (CoE)" to the Kyoto Immigration Bureau for processing. We are not sure when exactly we can obtain and send the CoE to you as it is totally up to the Immigration Office, however, we aim to send it to you latest by early September for fall semester and by early March for spring semester.

**Q22: I have dual nationality and one of these is Japanese. Which passport shall I use?**

Please use Japanese passport to enter Japan.

**Q23: I have dual nationality and none of these is Japanese. Which passport shall I use?**

It is up to you which passport you are going to use. However, please note that the passport you use for the application of the program and CoE/VISA application must be the same with the one you enter Japan.

**Q24: where can I apply for VISA?**

You can apply for VISA either at the Japanese embassy/consulate of your own country or country of residence.

## SCHOLARSHIP

**Q25: Is there any scholarship available other than JASSO scholarship?**

There is no other scholarship or financial aid which you can apply through Kyoto University. You might want to seek a way to get scholarship such as through your university or your government.

**Q26: I selected "no need" for JASSO scholarship on online application, but I changed my mind and wish to apply for it. What can I do?**

Please contact the IESMD office by e-mail.

**Q27: How do you select the recipients of JASSO scholarship?**

Nominees of JASSO scholarship will be selected by Kyoto University based on their academic record and financial condition and the final decision of the recipients will be made by JASSO. Students are not eligible to apply for JASSO scholarship if they will receive any other financial support more than 80,000 yen per month to study abroad or if they do not have the residence status of "Student", i.e. those who have Japanese nationality or permanent residency are not eligible to apply for JASSO scholarship.

## ONLINE APPLICATION SYSTEM

**Q28: I cannot complete the online application "Step 1". What can I do?**

Please check whether your input contains any character other than alphabet or not. If you cannot find any problem, please contact the IESMD office by e-mail.

**Q29: I entered wrong information in online application. What can I do?**

Please contact the IESMD office by e-mail.

**Q30: How can I fill out the form if I attended several elementary schools?**

Please fill in the information of the last school you attended and indicate other school names and period you have attended in brackets in "Name of School" columns.

e.g.

- Name of School: ABC School (DEF School: 2001.10 - 2003.9)
- Location: location of ABC School
- Length of officially required years for graduation: Indicate the total years normally required to graduate elementary school in your country
- Year and month of entrance and completion: Indicate the period you attended the ABC school

## OTHERS

**Q31: When can I get an acceptance letter?**

You will receive an acceptance letter in January for spring semester and in July for fall semester.

**Q32: Which campus (Yoshida, Katsura, Uji or other) will I most likely take courses at?**

Most of the courses for KUINEP and GE students are held at Yoshida campus unless you are enrolled in Graduate School of Engineering whose classrooms or professors' lab are mainly located in Katsura campus. If you are GESR student, please ask your supervisor directly.

**Q33: Should I apply for the dormitory?**

There are one on-campus and five off-campus International Houses of Kyoto University, and other dormitories are offered for exchange students. However, they are not guaranteed and are subject to availability due to limited housing capacity. Application period starts

around three months before their arrival. If you prefer to live in a private place such as an apartment, you are responsible to find one by yourself. You will receive detailed information on applying for dormitories after you are officially accepted for the program.

**Q34: How much is monthly living cost in Kyoto?**

It is around 80,000 yen on average.

**STATEMENT OF PURPOSE Only For General Exchange (GE) Program (GEA•GESR)**

(\*Students who apply for KUINEP do not need to submit this Form.)

In your statement, please explain the followings as specifically and concretely as possible:

- (a) **For both (GEA & GESR)** Describe your reasons for wanting to study at Kyoto University, and why this particular faculty/graduate school, and what you believe you will gain from it.
- (b) **Only for GEA (Special Auditor)** Describe the reason why you choose the courses based on your educational background at home university.
- (c) **Only for GESR (Special Research Student)** Describe the reason why you choose the research topic based on your educational background at home university.

The statement should be typed double-spaced and be of approximately 800 words in English (1200 letters in Japanese) length. Please attach an additional page(s), if necessary.

**Applicants who would like to be “GEA (Special Auditor)” in a Faculty/Graduate School and take courses taught in Japanese are required to write above (a), (b) in Japanese to show Japanese proficiency.**

Signature: \_\_\_\_\_

Date: \_\_\_\_\_  
Year / Month / Day

### Language Proficiency Statement

Exchange applicants who take classes offered in English should submit a valid TOEFL iBT or IELTS scores, **OR** this form, **including native English speakers**, regardless of whether whose institutions are located in an area where English is the first language or the institutions use English as the medium of instruction.

Exchange applicants who take classes offered in Japanese should submit a valid JLPT score with grade “N1” **OR** this form, **including native Japanese speakers**.

*Note: This form must be completed by the authorized representative of the applicant’s home institution.*

To: Kyoto University

Name of Institution: \_\_\_\_\_

Country of Institution: \_\_\_\_\_

Student’s Full Name: \_\_\_\_\_  
(Last Name) (First Name) (Middle Name)

I hereby confirm that (Please mark with ✓):

- He/she is native in **English**.
- English** is the medium of instruction of his/her home institution.  
His/her English language skills would enable him/her to take courses taught in English without experiencing difficulty.
- His/her **English** proficiency is equivalent to TOEFL iBT79 (IELTS 6.5) or above.  
His/her English language skills would enable him/her to take courses taught in English without experiencing difficulty.
- He/she is native in **Japanese**.
- His/her **Japanese** proficiency is equivalent to JLPT N1 or above.  
His/her Japanese language skills would enable him/her to take courses taught in Japanese without experiencing difficulty.

Signature \_\_\_\_\_

Name in print \_\_\_\_\_

Job Title or Position \_\_\_\_\_

Date \_\_\_\_\_

Year / Month / Day

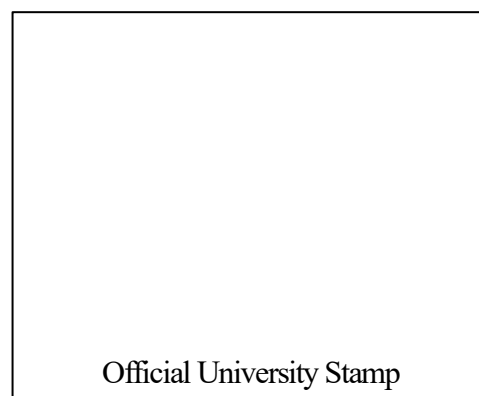



京都大学 大学間学生交流協定に基づく交換留学生（特別研究学生）受入内諾書

## Letter of Provisional Acceptance

(西暦) 年 月 日

(year / month / day)

Home University 所属大学 (英文) \_\_\_\_\_

Name of student 学生氏名 (英文) \_\_\_\_\_ 殿

京都大学との大学間学生交流協定に基づく交換留学生（特別研究学生）として貴殿が所属大学から京都大学へ推薦された場合、下記のとおり、受入れることを内諾します。

You will be tentatively accepted in accordance with the details below on condition that you are nominated by your home university to Kyoto University as an exchange student (GESR) under the university-wide student agreement.

## 記 (Details)

Name of University 受入れ大学 KYOTO UNIVERISTY

Name of Graduate School 研究科 (英文) \_\_\_\_\_

Expected Academic Advisor 指導予定教員 (英文) \_\_\_\_\_

Job Title 指導予定教員の職位 (英文) \_\_\_\_\_

Exchange Period 受入れ期間 From (Year) \_\_\_\_\_ (Month) 4月 or 10月

(※該当するものに○印を付してください)

For 1 or 2 semester(s)

Signature by expected academic advisor

指導予定教員の署名

--

## 【出願者への注意事項 Important Notice to Applicants】

- 1) 希望する指導教員から、この受入内諾書が返送されたら所属大学に提出してください。
- 2) 受入内諾書は、受入れ部局選定のために使用します。受入内諾書をもって、交換留学生としての受入れが決定するものではありません。
- 1) When this letter is returned to you by the expected academic advisor, please submit it to your home university.
- 2) Such acceptance letter from the expected academic advisor will be used solely by Kyoto University IESMD office for determining the graduate school to which you will be accepted after passing the exchange student screening. Such letters do not certify your acceptance as an exchange student.

## 【指導予定教員へのお願い Notes for Expected Academic Advisor】

大学間学生交流協定に基づく交換留学生の内、研究を主たる目的とする学生を特別研究学生として受入れています。学生の指導希望研究分野等を確認の上、受入れを内諾いただける場合は、受入内諾書に必要事項を記入の上、写し (PDF 可) をメール等で学生に送付願います。また、本紙はお手元に保管していただきますようお願いいたします。

なお、正式な受入依頼は、春学期受入れ開始の場合は前年度 10 月末頃、秋学期受入れ開始の場合は同年度 4 月末頃に国際・共通教育推進部国際教育交流課 (inbound.exchange@mail2.adm.kyoto-u.ac.jp) からご所属の部局事務担当を通じて送付させていただきます。協定校や学生の事情により交換留学の出願が取下げとなる場合がありますので、予めご了承くださいませよう願います。



Grade Reporting Form for JASSO Scholarship Application

**This form should be filled out by Home University** and submitted to Kyoto University before matriculation along with other application documents if a student wishes to apply for JASSO scholarship. If this form is not submitted by Home University, Kyoto University will not recommend the student to JASSO as a candidate for scholarship.

1) Name of Applicant

2) Is she/he having difficulty on paying his/her own expenses during the exchange period?

\*This answer may be considered when we select Jasso recipients.

3) Select one evaluation scale

\*If you don't select the pattern, it will generate an error on 4)

Pattern 1		Excellent	Good	Sufficient	Fail
Pattern 2		A	B	C	F
Pattern 3		100-80	79-70	69-60	59-
Pattern 4	100-90	89-80	79-70	69-60	59-
Pattern 5	S	A	B	C	F
Pattern 6	A	B	C	D	F



#2) & #3)  
select from  
pulldown menus  
(DO NOT type)  
#4) Evaluation

4) Fill out the table with grades of courses taken within the most recent 12 months.

This form calculate GPA automatically. No hand writing is acceptable.

\*Please exclude grades of courses with no marks. (e.g. "Pass")

	Course Code	Name of Courses	Credits	Evaluation
1				
2				
3				
4				
5				
6				
7				
8				
9				
10				
11				
12				
13				
14				
15				
16				
17				
18				
19				
20				
21				
22				
23				
24				
25				

5) Name of University

Name of Applicant

Name of Coordinator

6) Please print out this form, sign and submit together with other application documents by the dead-line.

Date

Coordinator's Signature

For Kyoto University office use

Total Credits	0
Total Points	0
Average	#DIV/0!

\*Please disregard if it shows error